

Instructions for Contour Beds



Please identify the listed items before installation.

Hardware included:

- ¼ - 20 x 35mm hex bolts (18)
- ¼ - 20 Philips flat head ¾" bolts (32)
- Allen wrench (1)
- Jointing plate (4)

Components included:

- Headboard (1)
- HDBD deck ASM (1)
- FTBD deck ASM (1)
- Support leg assembly (1)
- Walnut/ash leg ASM (2)
- Shelves (opt.)

Contour bed without Shelf Nightstand

- King
- Queen
- Cal King

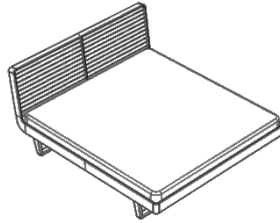

Contour bed with Shelf Nightstand(s)

- King
- Queen
- Cal King

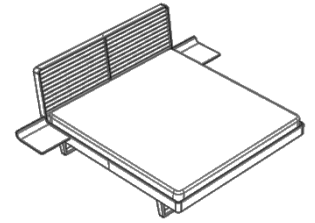

Tools required | Allen wrench

Notice: Beds must be disassembled before moving to avoid damage. Never attempt to move the bed while it is assembled. Failure to do so would void the warranty.



Step 1: Install the headboard base

Align and loosely attach a *walnut/ash leg assembly* to the *headboard deck assembly* with the provided ¼ - 20 x 35mm hex bolts. Then align and attach the *support leg assembly* to the *headboard deck assembly* with provided ¼ - 20 x 35mm hex bolt (**Figure 1**).

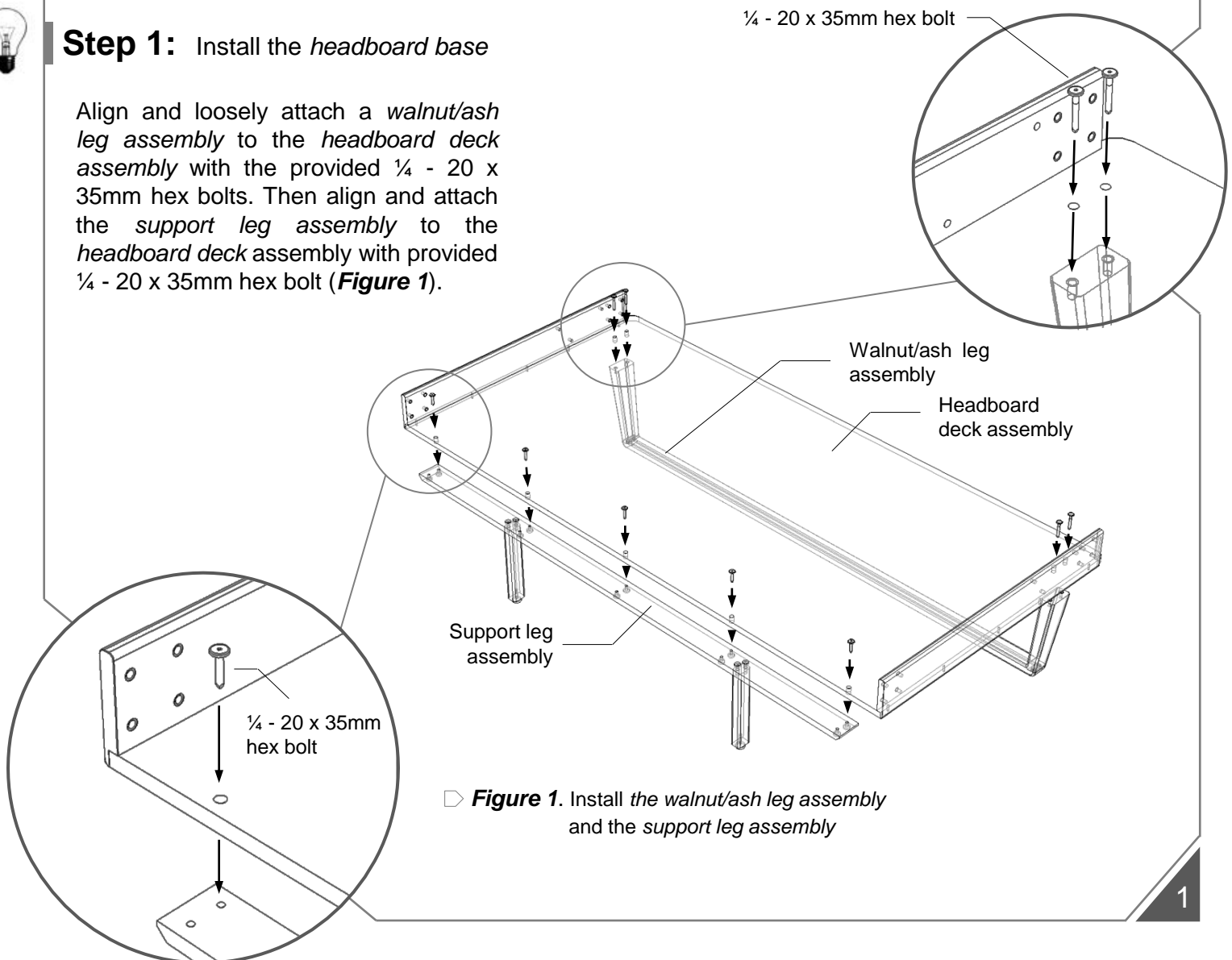



Step 2: Install the *footboard base*

Attach the other *walnut/ash leg assembly* to the *footboard deck assembly* with $\frac{1}{4}$ - 20 x 35mm hex bolts (**Figure 2**).

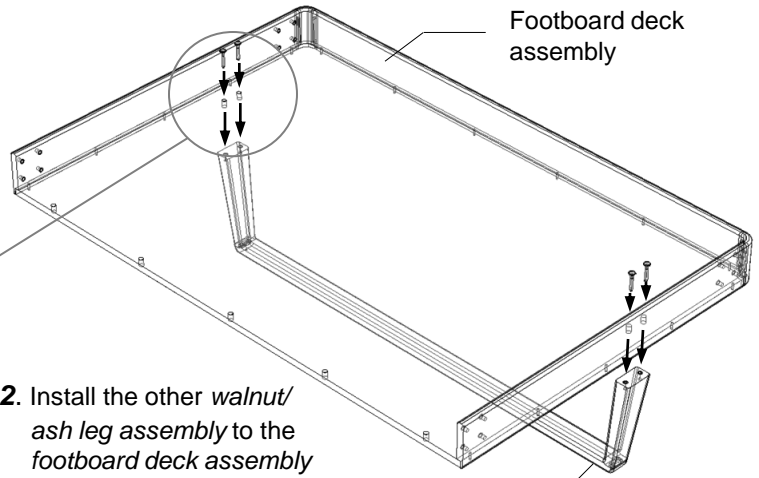

▷ **Figure 2.** Install the other *walnut/ash leg assembly* to the *footboard deck assembly*

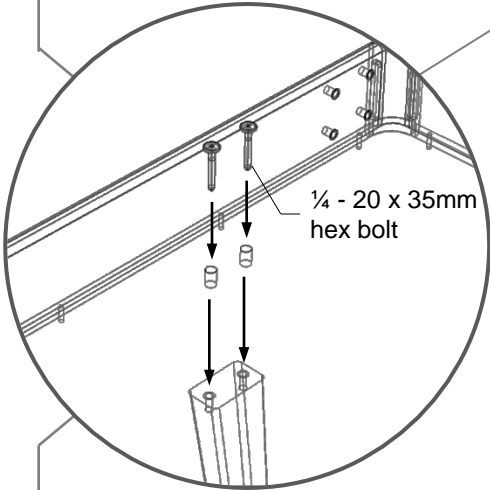

Walnut/ash leg assembly

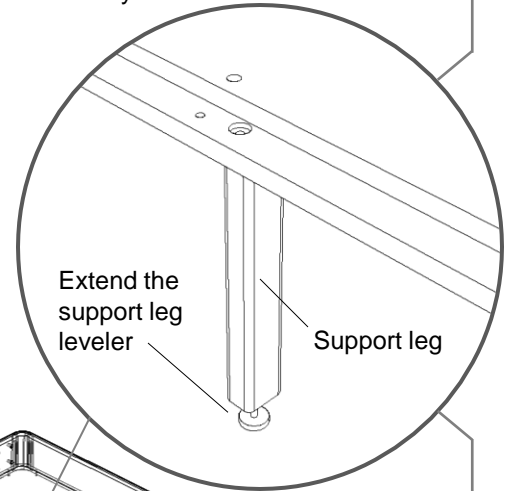

Extend the support leg leveler

Support leg

Step 3: Mount *footboard base* to *headboard base*

Attach the *footboard base* to the *support leg brace* on the *headboard base* with the provided $\frac{1}{4}$ - 20 x 35mm hex bolts (**Figure 3**). Retract the support leg leveler slightly so that it only makes contact with the floor when weight is applied to the fully assembled bed.

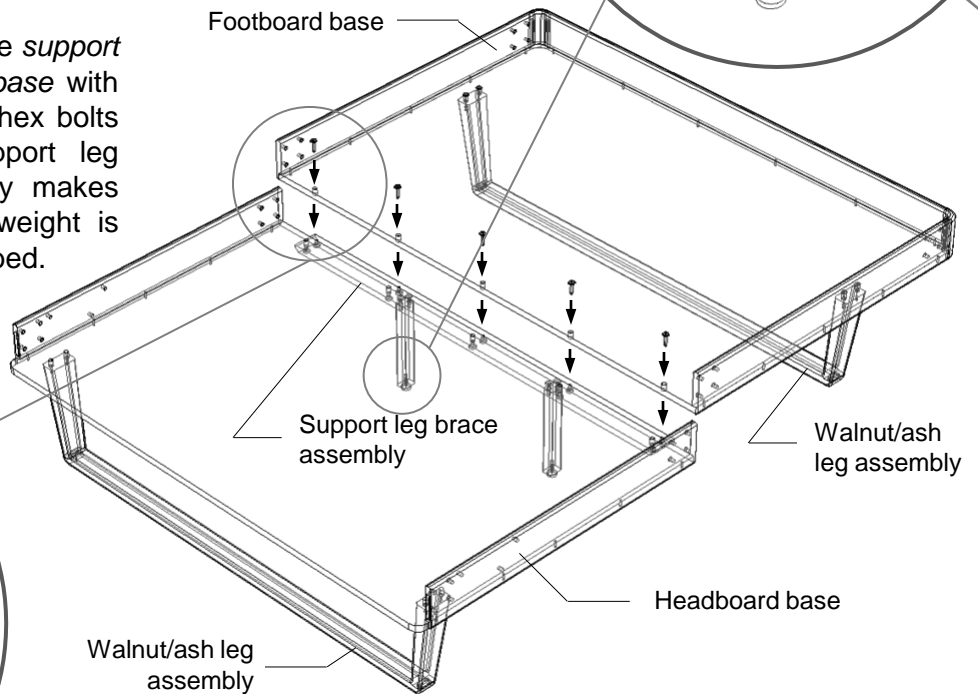

Footboard base

Support leg brace assembly

Walnut/ash leg assembly

Headboard base

Walnut/ash leg assembly

▷ **Figure 3.** Connect the *footboard base* with *headboard base*

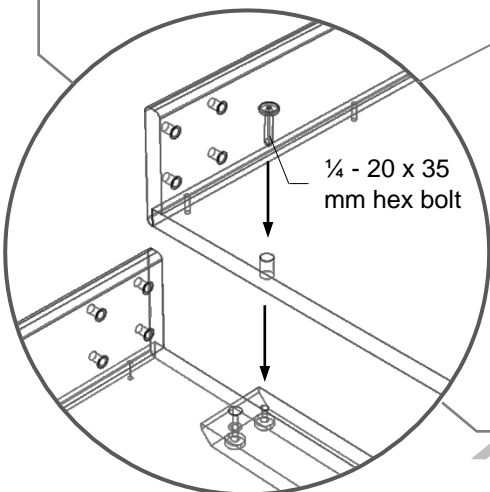

$\frac{1}{4}$ - 20 x 35 mm hex bolt

Step 4: Install the *jointing plates*

After connecting *headboard base* with the *footboard base*, mount the *jointing plates* to each side of the deck assembly with $\frac{1}{4}$ " Phil flat head $\frac{3}{4}$ " bolts (**Figure 4**).

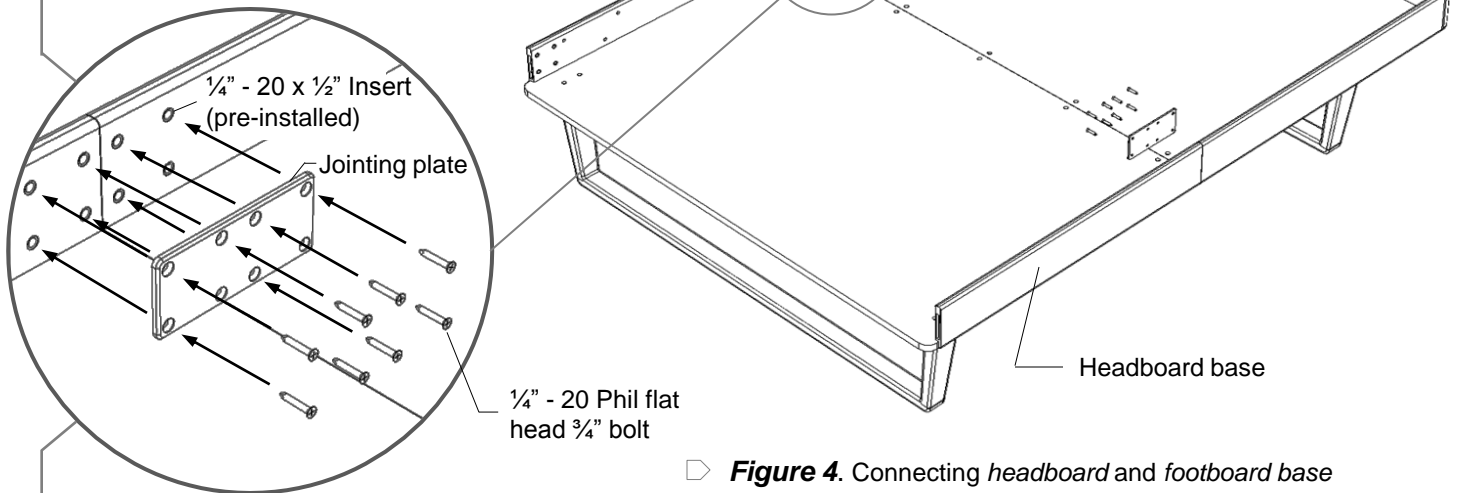

▷ **Figure 4.** Connecting *headboard* and *footboard base* with *jointing plates*

Step 5: Mount *headboard assembly* to *headboard base*

Align the tenon at the *headboard assembly* end with the *headboard base* tenon slot. Connect the *headboard* end and *headboard base* end with the *jointing plates*. Loosely tighten the plates with $\frac{1}{4}$ " - 20 Phil flat head $\frac{3}{4}$ " bolts. Once all the bolts are in place, fully tighten all the bolts (**Figure 5**).

▽ **Figure 5.**

Connect the *headboard* to the *headboard base*

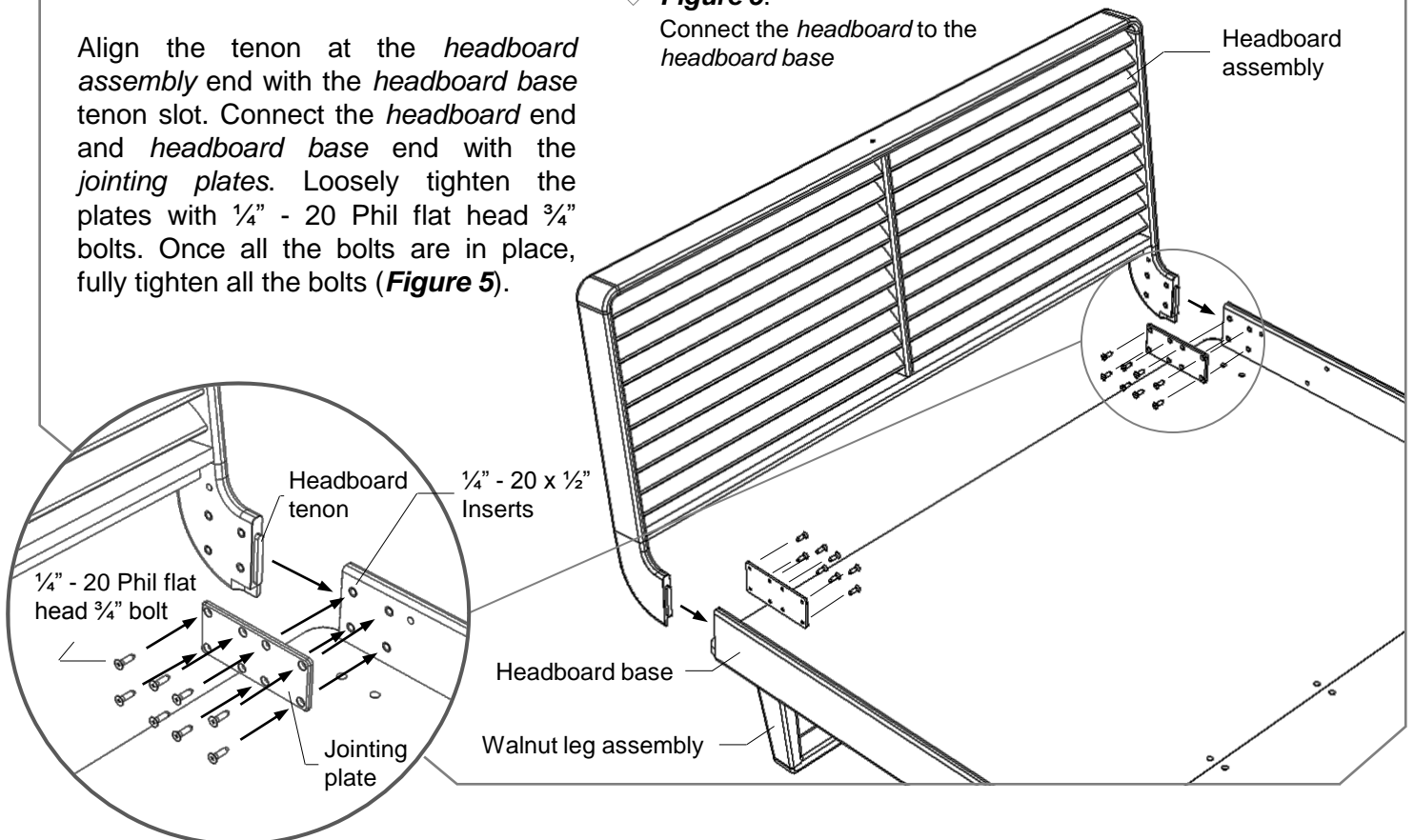

Care Instructions

To care for and preserve the finish on your new Copeland Furniture piece, please keep the following recommendations in mind.

- While our furniture has been finished with a durable top coat, the surface may be sensitive to dents and abrasions during the first 30 days in your home.
- Treat the surface finish gently so it does not dent or chip. Tape or stickers should not be put on the finish.
- For general care use a soft cloth to dust the furniture.
- Use damp cloth with a mild soap to clean-up spills or dirt. Dry the surface thoroughly.
- Please do not use any polishes, waxes or solvents to clean the surface of the furniture. This holds true for new Copeland Furniture pieces as well as items you may already have in your home.
- Please do not place any candles directly on the surface of your furniture. The perfumes and dyes in the candles may penetrate the finish.
- Beds must be disassembled before moving to avoid damage. Never attempt to move the bed while it is assembled.

