

# Instructions for Keaton Beds

Please identify the listed items before installation.

## Hardware included:

- ¼ - 20 x 50mm hex bolts (8)
- Allen wrench (1)
- Platform hardware (1)
- Siderail hardware (1)

## Components included:

- Upholstered headboard (1)
- Upholstered footboard (1)
- Base assembly (2)
- Siderail R (1)
- Platform kit (1)
- 6" support block (1)
- Siderail L (1)

**NOTICE:** Beds must be disassembled before moving to avoid damage. Never attempt to move the bed while it is assembled. Failure to do so would void the warranty.

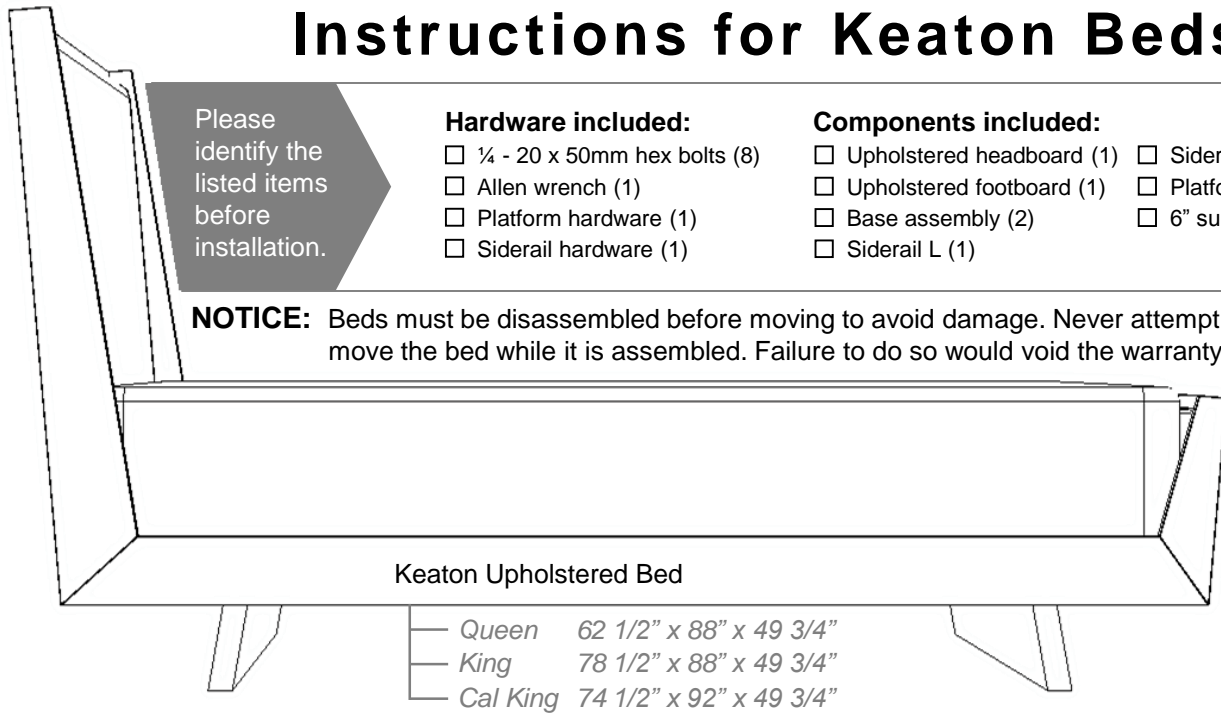

Tools required | Allen wrench (provided)

## Step 1: Attach the Base Assemblies to the Siderails

Align the holes on each end of the Base Plate with the holes on siderail cleats (**Figure 1**). Insert the 2" (50mm) hex bolts from the top of the cleats and tighten with the provided Allen wrench. Make sure the tip of the leg is facing out.

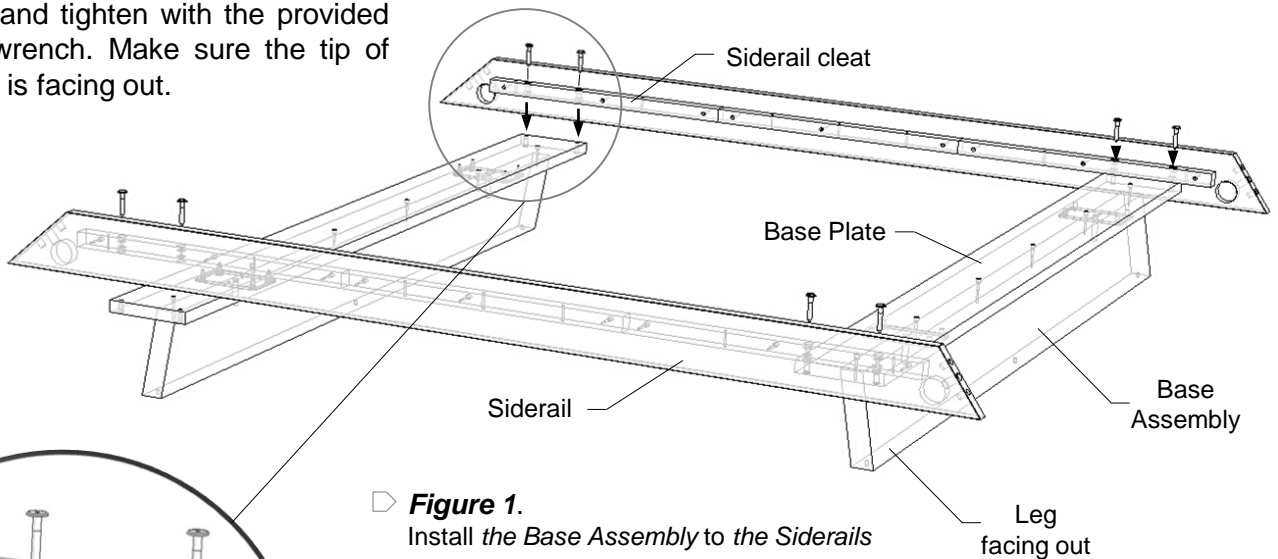

Figure 1.

Install the Base Assembly to the Siderails

¼ - 20 x 50mm hex bolt

Siderail Cleat

Base Plate

**Step 2:** Use the following steps to attach the headboard and footboard to the siderails (**Figure 2**)

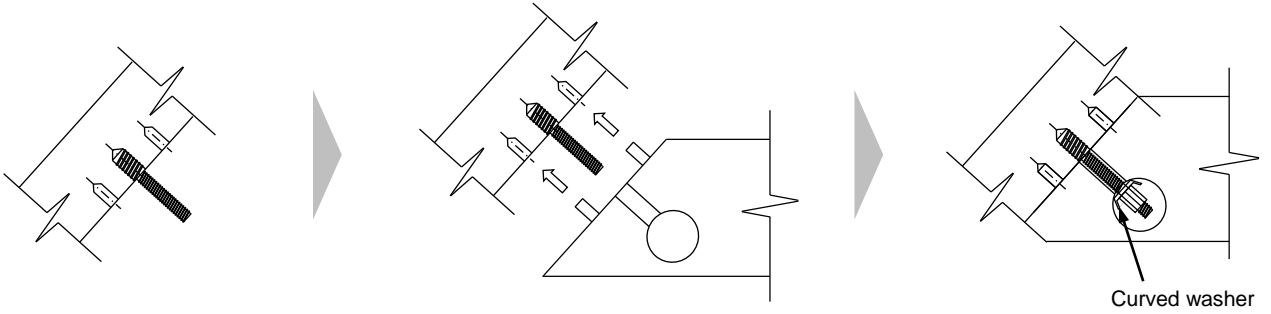

Screw the threaded stud into the insert in the *headboard leg* until it stops.

Slide the rail into mating holes for dowels on the *headboard side*.

Slide the curved washer and the nut in place as shown, and tighten the nut with the wrench provided in the *side rail hardware kit*.

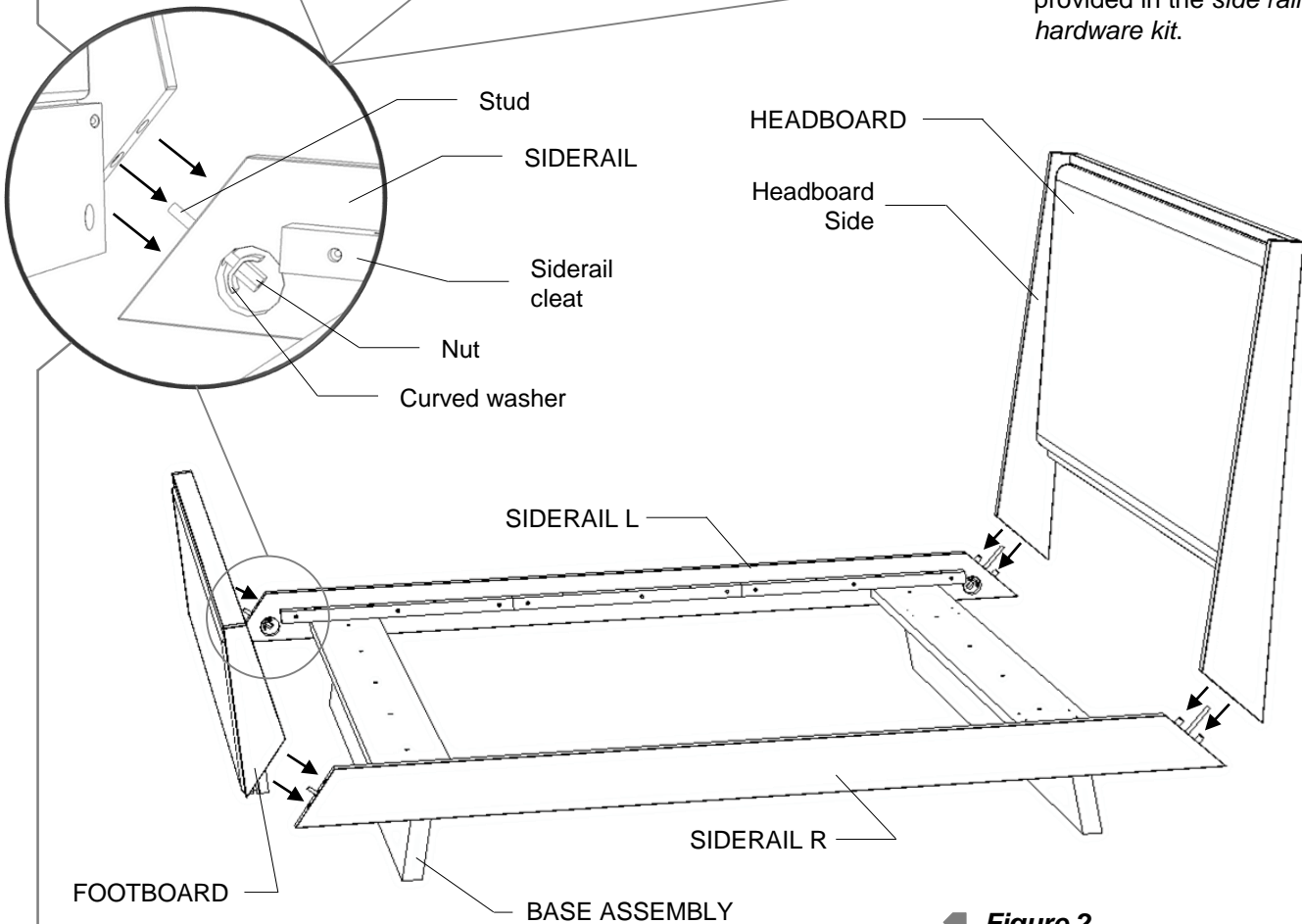

**Figure 2.**  
Assemble siderails,  
headboard, and footboard

**Step 3:** Install the *support leg* on the *middle platform assembly*

Align the holes on the *support leg* and *middle platform assembly* spine. Tighten with 1 3/4" pan head screw (**Figure 3**). Make sure to retract the *support leg leveler* slightly so that it only makes contact with the floor when weight is applied to the fully assembled bed.

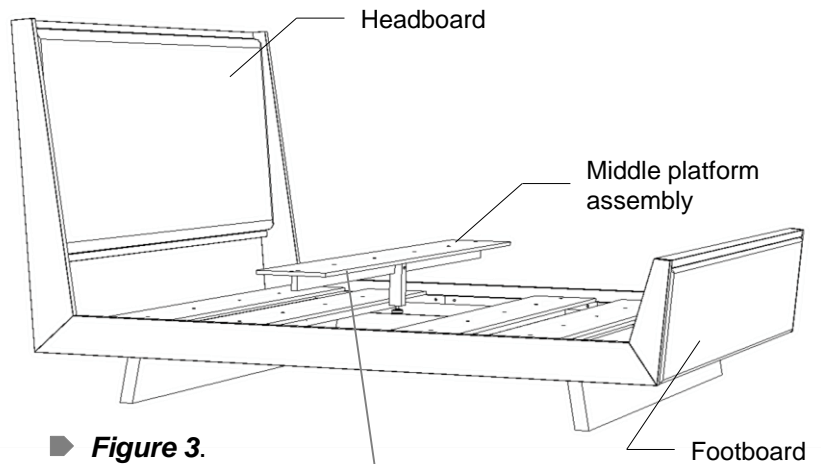

► **Figure 3.**  
Install *support leg*  
on middle platform

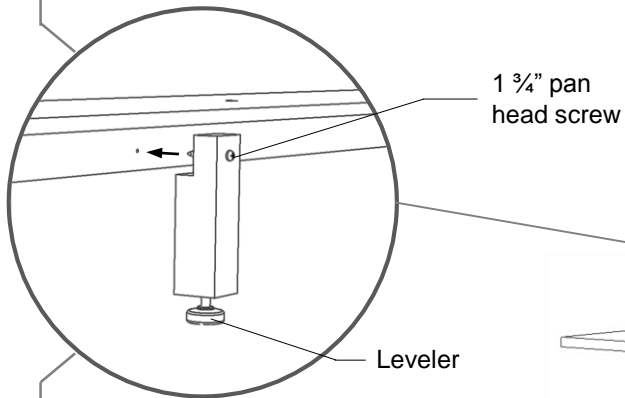

1 3/4" pan  
head screw

Leveler

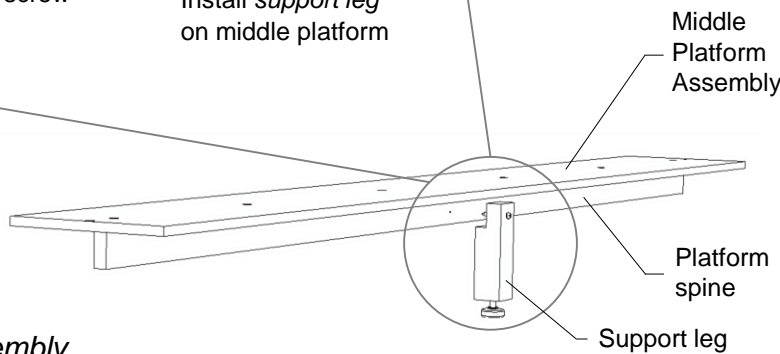

**Step 4:** Install the *platform assembly*

Align the holes on each end of the *platform assembly* and the holes on the *side rail cleats* (**Figure 4**). Tighten each *platform assembly* and *side rail* with 1 1/2" pan head screws.

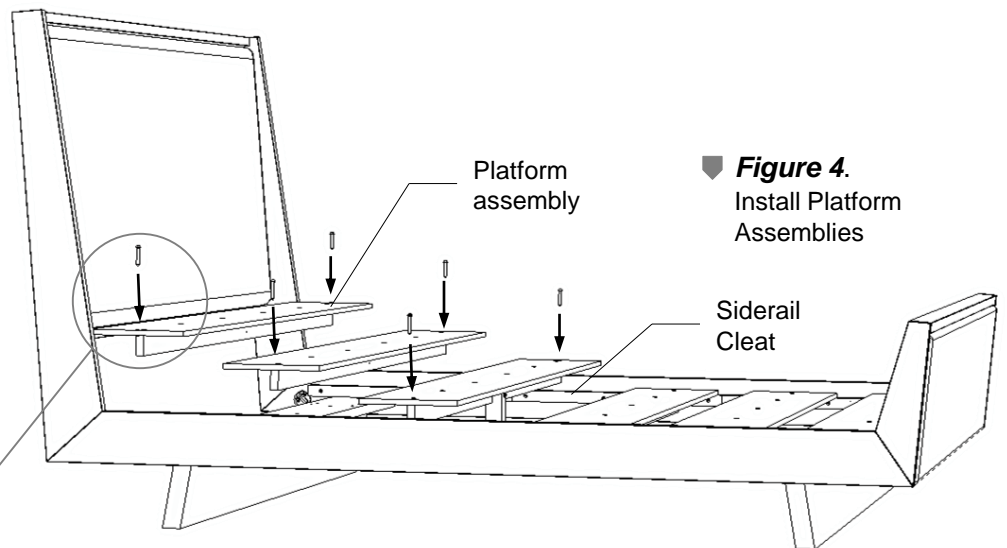

► **Figure 4.**  
Install Platform  
Assemblies

1 1/2" pan  
head screw

Siderail  
Cleat

Siderail  
Cleat

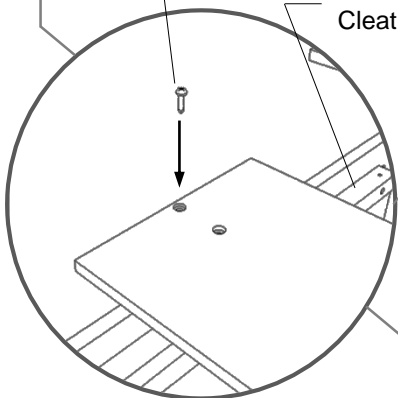

## Care Instructions

To care for and preserve the finish on your new Copeland Furniture piece, please keep the following recommendations in mind.

- While our furniture has been finished with a durable top coat, the surface may be sensitive to dents and abrasions during the first 30 days in your home.
- Treat the surface finish gently so it does not dent or chip. Tape or stickers should not be put on the finish.
- For general care use a soft cloth to dust the furniture.
- Use damp cloth with a mild soap to clean-up spills or dirt. Dry the surface thoroughly.
- Please do not use any polishes, waxes or solvents to clean the surface of the furniture. This holds true for new Copeland Furniture pieces as well as items you may already have in your home.
- Please do not place any candles directly on the surface of your furniture. The perfumes and dyes in the candles may penetrate the finish.
- Beds must be disassembled before moving to avoid damage. Never attempt to move the bed while it is assembled.

